

CliniLever® Hospital Single Lever Basin Mixer

PRODUCT CODE:

- TM-BASCP
- TM-BASCPR
- TM-BASCPY
- TM-BASCPD (with disabled lever)
- TM-BASCPDY (with disabled lever)



SPECIFICATIONS

- Chrome plated brass construction
- Clean hygienic design
- Low maintenance and easy to operate
- Smooth round designs to facilitate easy cleaning and help reduce dirt and bacteria growth.

IMPORTANT: All CliniLever® Taps are tested in accordance with AS/NZS 3718 and leave our premises in good working order.

WARNINGS: Special attentions to be paid on notes, photos, images, or drawings of assembly steps marked with the warning symbol.



TECHNICAL DATA

Inlet	½" BSP – Female (Flexi-hoses)	
Outlet	Laminar Flow Aerator	
Headwork	Ceramic Cartridge	
Working Pressure Range (kPa)	Min	150
	Max	500
Working Temperature Range (°C)	Min	10
	Max	80
Nominal Flow Rate (LPM)	5.77	
Construction	DZR Brass	
Finish	Chrome	
NOTE: Galvin Engineering continually strive to improve their products. Specifications may change without notice.		

DIMENSIONS

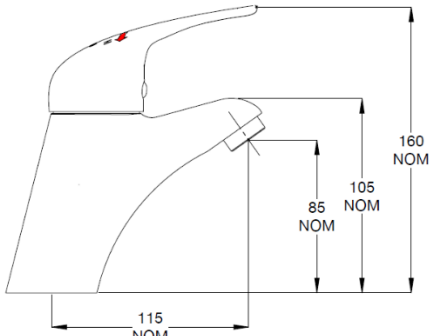
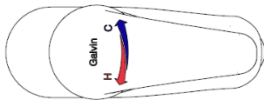

TM-BASCP/TM-BASCPR/TM-BASCPY

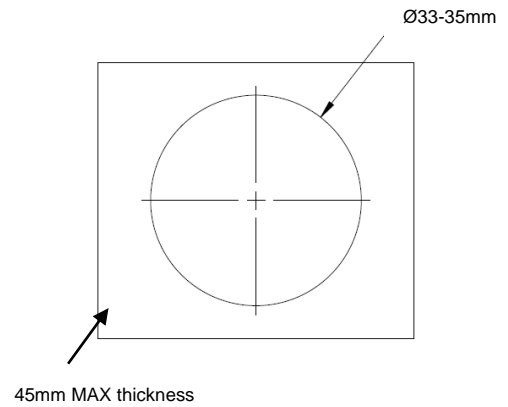
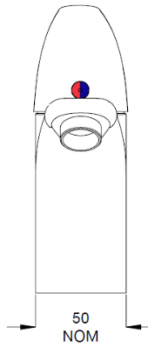

⚠ Deck Dimensions

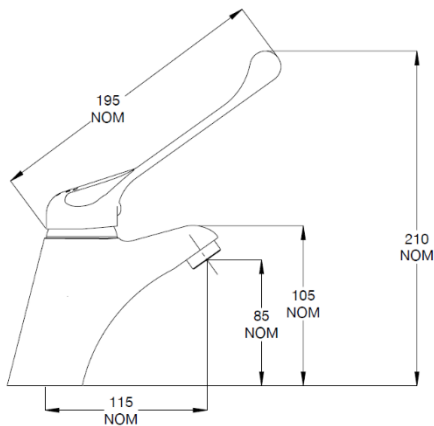
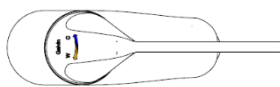

TM-BASCPD/TM-BASCPDY

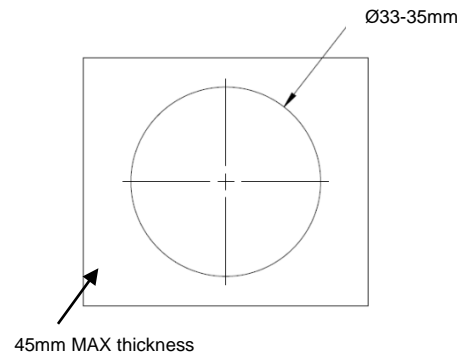
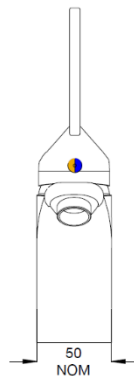

⚠ Deck Dimensions

PRE-INSTALLATION

- All pipework must be thoroughly flushed prior to installation, as foreign materials may block the flow regulating device and reduce the flow of water.
- Not suitable for gravity fed systems.
- Mixer is fitted with a 6 L/min flow regulated laminar flow insert. This low flow rate may not be suitable for connection to some Instantaneous Gas Water Heaters, some Tempering Valves, some Solar Water Heaters and some Thermostatic Mixing Valves.
- Check with the manufacturers of these products
- Isolating stop valves are recommended to be fitted to the inlet connections

INSTALLATION

INSTALLATION COMPLIANCE: Galvin Engineering products must be installed in accordance with these installation instructions and in accordance with AS/NZS 3500, the PCA and your local regulatory requirements. Water and/or electrical supply conditions must also comply to the applicable national and/or state standards. Failing to comply with these provisions shall void the product warranty and may affect the performance of the product.

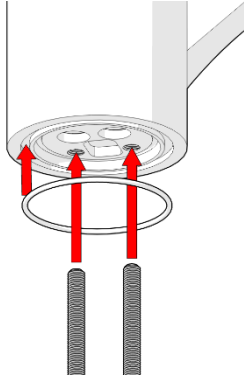

1. Fit O-ring and Studs

- Fit O-ring into groove under the mixer body.
- Screw studs under the mixer body

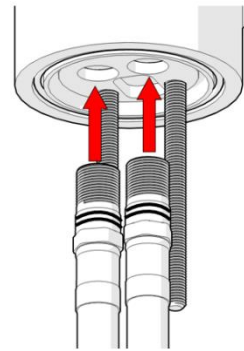

2. Fit flexible tails

- Apply AS4020 approved lubricant to O-rings for the tails and attach them to the tails before fitting it to the mixer body.
- Pass flexible tail with red and blue indication up through deck hole and install into holes marked with 'H' and 'C' respectively under the mixer body. Tighten both tails firmly by hand.

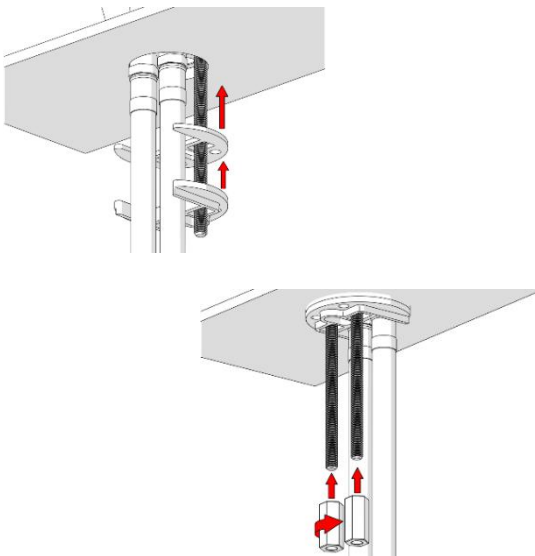

3. Secure Tap

- Place mixer over vanity cut out, then fit gasket and fixing plate over studs.
- Screw on fixing nuts and position mixer as required then tighten the fixing nuts.

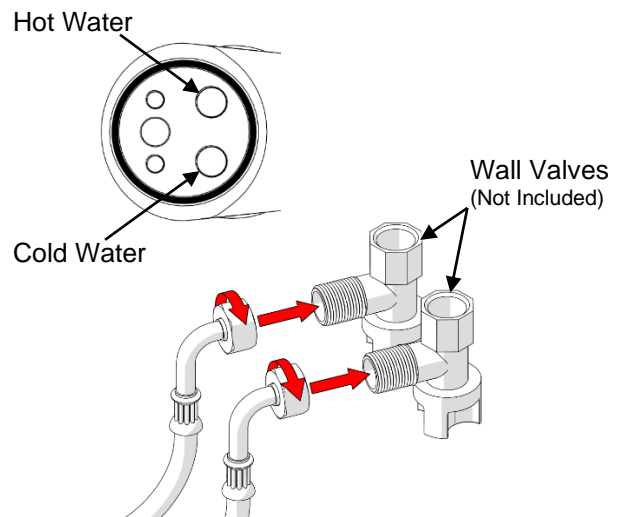

4. Connect water and test

- Connect the flexible tails to the hot and cold isolating stop valves, taking care that flexible tails are not kinked, twisted or in tension as they are tightened

REPLACE CARTRIDGE

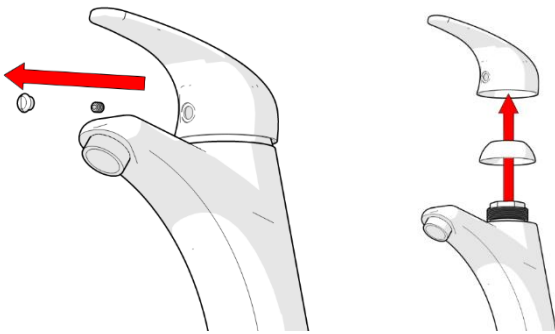

1. Remove indicator plug, handle and cap

- Turn off hot and cold water supplies at isolating valves.
- Remove indicator plug.
- Using 2.5mm allen key, loosen screw and remove handle.
- Remove cap taking care not to damage the decorative finish.

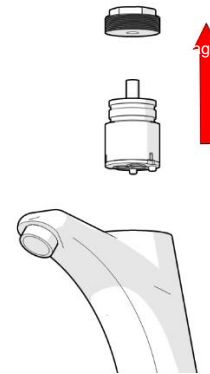

2. Take out old cartridge

- Unscrew nut and lift out old cartridge.
- Clean internal mixer body before installing new cartridge.

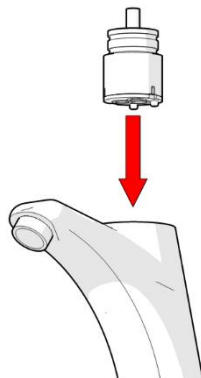

3. Insert new cartridge

- Fit new cartridge into mixer body, taking care that two lugs on base of cartridge fit into mating holes in mixer body

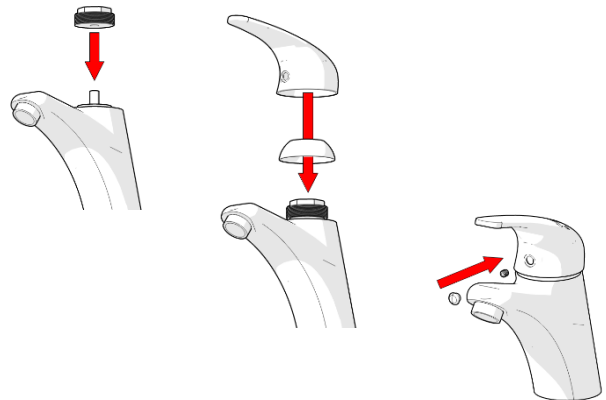

4. Reassemble

- Reassemble by reversing steps 1-2.

Note: Nut must be tightened to a torque of 12-13 Nm

5. Connect water and check for correct operation

- Turn on isolating stop valves and check operation.

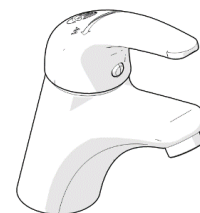

ADJUSTING THE ANTI-SCALD STOP RING

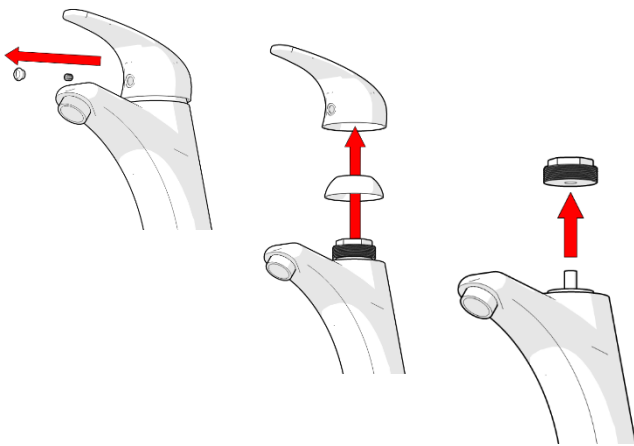

1. Remove indicator plug, handle, cap and nut

- Turn off hot and cold water supplies at isolating taps.
- Remove indicator plug.
- Using 2.5mm allen key, loosen screw and remove handle.
- Remove cap and unscrew nut taking care not to damage the decorative finish.

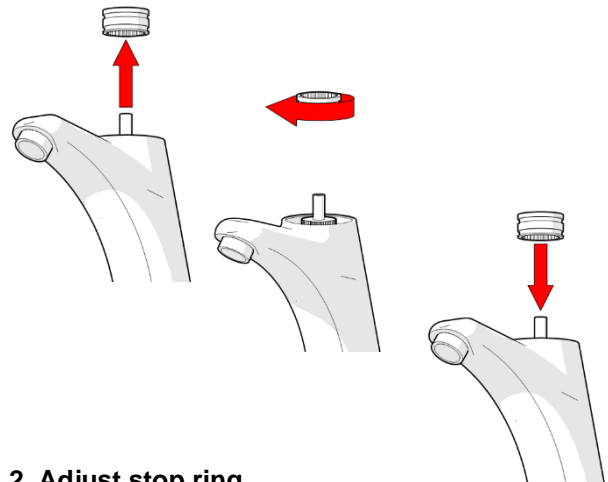

2. Adjust stop ring

- Using a small screwdriver, carefully remove the red stop ring and adjust it in an anti-clockwise direction as required so that the teeth in the stop ring engage with the teeth on the cartridge
- As a guide, rotate the stop ring by 1 spline in an anti-clockwise direction. This will restrict the handle movement in the hot water direction by 8 degrees of rotation. Push the stop ring fully down.

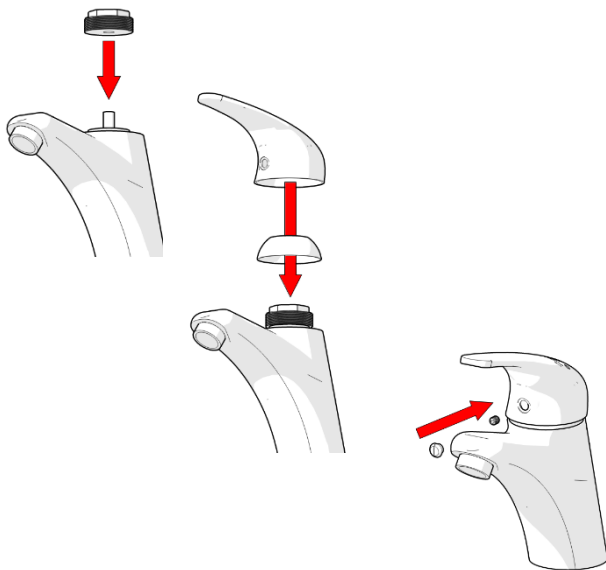

3. Reassemble

- Reassemble the nut, cap, handle, screw and plug indicator.
- Make sure the handle is fully pushed down.

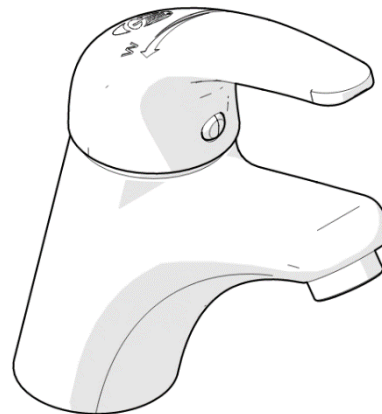

4. Check for correct temperature

- Check the hot water temperature with the handle in the fully open hot water position. If required adjust the stop ring until a satisfactory hot water temperature is achieved

REPLACE AERATOR INSERT

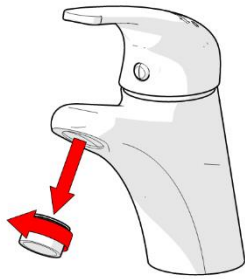

1. Remove aerator housing

- Carefully remove aerator housing from mixer body taking care not to damage the decorative finish.

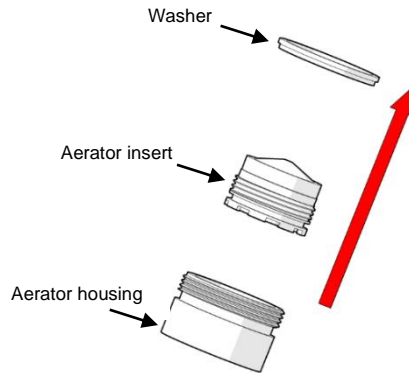

2. Remove old aerator insert

- Remove washer and old aerator insert from aerator housing.
- Check that aerator housing is clean and clean any debris that is blocking the flow.

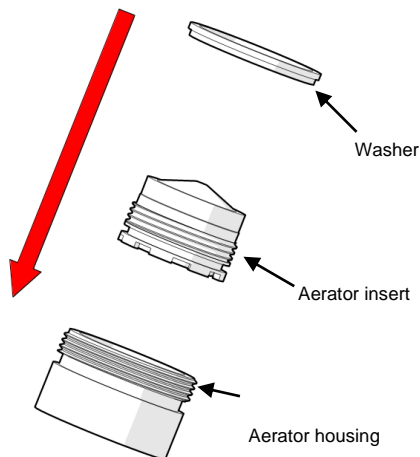

3. Fit new aerator insert

- Fit new aerator insert into aerator housing followed by washer.

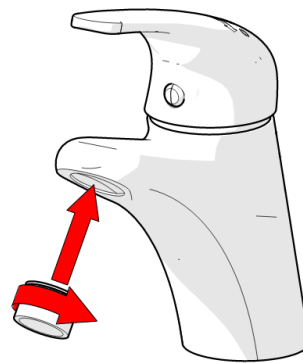

4. Return aerator housing

- Screw assembly into mixer body and tighten securely (to prevent removal by hand)

5. Check for correct operation

- Turn on isolating stop taps and check operation.



REPLACE HANDLE

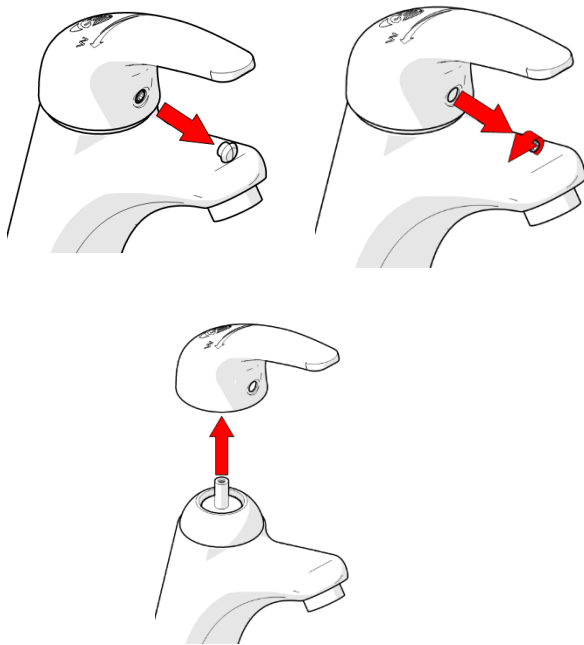

1. Remove the handle

- Remove indicator button.
- Using the Allen key provided, loosen the screw as shown.
- Remove the existing handle as shown.

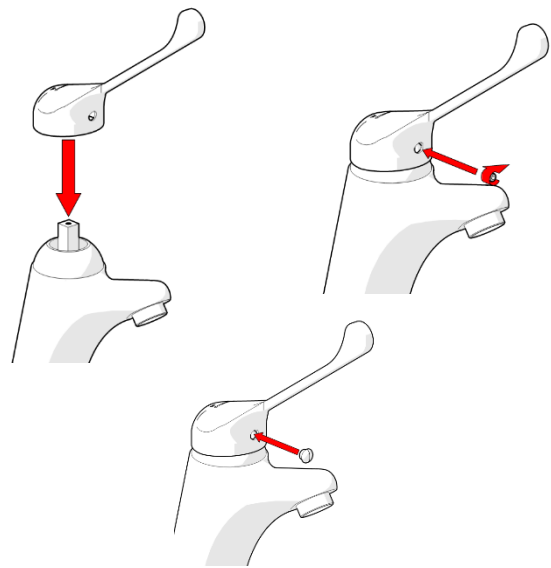

2. Fit the new handle

- Remove indicator button from the new handle.
- Using allen key provided loosen screw as shown.
- Fit the new handle onto the mixer body. Tighten the screw and install the indicator plug.

3. Testing

- Once fitted turn on water and check for leaks and correct operation



TROUBLESHOOTING		
PROBLEM	CAUSE	RECTIFICATION
Tap is leaking	Cartridge damaged	Remove and inspect the cartridge, remove debris and/or replace if damaged
	Tap incorrectly installed	Follow the installation steps above when fitting the tap.
Tap has inconsistent flow	Blocked flow regulator	Follow the instructions above to remove flow regulator from the body and check for debris. Install an inline strainer to stop further blockages.
Tap moves on basin	Insufficiently tightened	Follow the steps above in relation to tightening the installation.
Water temperature is opposite to the handle markings	Inlet hoses connected incorrectly	Connect the inlet hoses to the correct inlets as shown above.

WARRANTY
<p>The warranty set forth herein is given expressly and is the only warranty given by the Galvin Engineering Pty Ltd. With respect to the product, Galvin Engineering Pty Ltd makes no other warranties, express or implied. Galvin Engineering Pty. Ltd. hereby specifically disclaims all other warranties, express or implied, including but not limited to the implied warranties of merchantability and fitness for a particular purpose.</p> <p>Galvin Engineering Pty Ltd products are covered under our manufacturer’s warranty available for download from www.galvinengineering.com.au Galvin Engineering Pty Ltd expressly warrants that the product is free from operational defects in workmanship and materials for the warranty period as shown on the schedule in the manufacturer’s warranty. During the warranty period, Galvin Engineering will replace or repair any defective products manufactured by Galvin Engineering without charge, so long as the terms of the Manufacturer’s warranty are complied with.</p> <p>The remedy described in the first paragraph of this warranty shall constitute the sole and exclusive remedy for breach of warranty, and Galvin Engineering Pty Ltd shall not be responsible for any incidental, special or consequential damages, including without limitation, lost profits or the cost of repairing or replacing other property which is damaged if this product does not work properly, other costs resulting from labour charges, delays, vandalism, negligence, fouling caused by foreign material, damage from adverse water conditions, chemical, electrical or any other circumstances over which Galvin Engineering has no control. This warranty shall be invalidated by any abuse, misuse, misapplication, improper installation or improper maintenance or alteration of the product.</p>